



# **Hydraulic Pump Series F1**

**Fixed Displacement**



*Catalog 9129 8201-02  
April, 1999 GB*



<b>Content</b>	<b>Page</b>
General information	3
Specifications	4
Pump and line selection	5
Ordering code	5
Standard versions	5
Installation dimensions	6
Installation and start-up	7

## **Conversion factors**

1 kg	2.20 lb
1 N	0.225 lbf
1 Nm	0.738 lbf ft
1 bar	14.5 psi
1 l	0.264 US gallon
1 cm <sup>3</sup>	0.061 cu in
1 mm	0.039 in
$\frac{9}{5} \text{ }^{\circ}\text{C} + 32$	$1^{\circ}\text{F}$

Parker Hannifin reserves the right to modify products without prior notice.

Even though the brochure is revised and updated continuously, there is always a possibility of errors.

For more detailed information about the products, please contact Parker Hannifin (VOAC Hydraulics Div.)

## F1

F1, the 'truck pump', has been developed from our well known series F11 hydraulic pumps/motors. It is specifically designed for various truck applications and offers many unbeatable advantages for forest cranes, hook loaders, tippers, skip loaders, cargo cranes, and others.

Series F1 is very efficient. Its design is simple with small installation dimensions and few moving parts which contributes to high reliability and an altogether simpler and less expensive installation.

- High output power despite small envelope size
- High overall efficiency
- Operating pressures to 350 bar
- Compact and low weight
- Can be installed above the reservoir oil level
- Tolerates low temperatures
- Easy to service and dependable.

All six frame sizes of series F1 have the same shaft end and mounting flange dimensions, and follow the current ISO standard. Consequently, the F1 can easily be installed on most European trucks.

Our product program also contains a series of PTO's for the F1 pump that fit most truck gearboxes on the market.

## Design

### Spherical pistons

The lightweight, spherical piston is the key to the so called 40° design, offering many advantages such as:

- Compactness
- Simple construction
- High pressure capability.

### Laminated piston rings

The three part, laminated piston ring offers:

- Low internal leakage
- Non-sensitivity to thermal shocks.

### Dependable piston locking

The specially formed piston ball end is secured in the input shaft socket which means:

- Fewer parts
- Increased dependability
- Simple assembly and disassembly.

### Positive synchronisation

The timing gear between the cylinder barrel and the input shaft contributes to the reliability of the pump.

- Tolerates diesel engine vibrations
- Less piston wear is experienced.

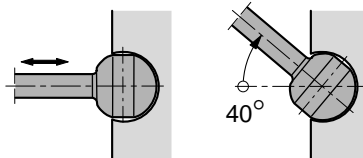
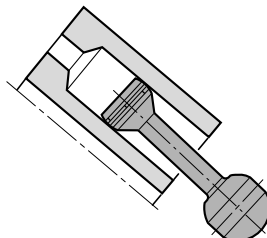
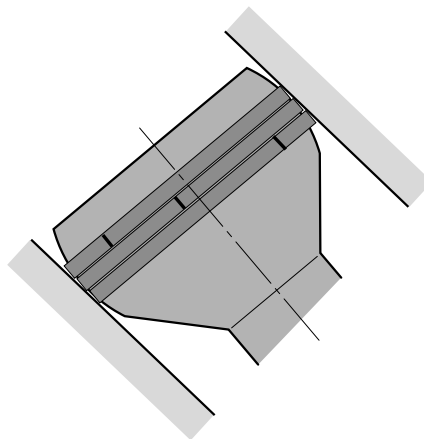

### Stands external shaft loads

The robust roller bearings permit a pulley or a gear to be mounted directly on the pump shaft without the use of additional bearings.

### Few moving parts

Series F1 has a very simple design with few moving parts:

- Cylinder barrel with hold-down device
- Pistons with piston rings
- Shaft with timing gear and bearings.

### High overall efficiency

The spherical piston with laminated piston ring offers low leakage and has low mechanical losses.

It leads to a lower power requirement and higher fuel efficiency.

### Long life

The piston locking, the timing gear, and the small number of parts contribute to the F1's reputation as a very rugged pump with long life, high reliability, and low service requirement.

## Specifications

Frame size	F1-20	F1-30	F1-40	F1-60	F1-80	F1-110
Displacement [cm <sup>3</sup> /rev]	19.0	28.1	38.7	58.2	78.2	110.1
Max operating pressure [bar]	350	350	350	350	350	350
Shaft speed [rpm]						
Short circuited pump (low press.)	3000	2700	2400	2200	2000	1800
Max selfpriming speed	2300	2000	1800	1500	1300	1300
Input power [kW]						
Max intermittent	28	36	46	56	66	88
Max continuous	20	26	33	40	47	66
Weight [kg]	6.7	6.9	9.5	10	14	18

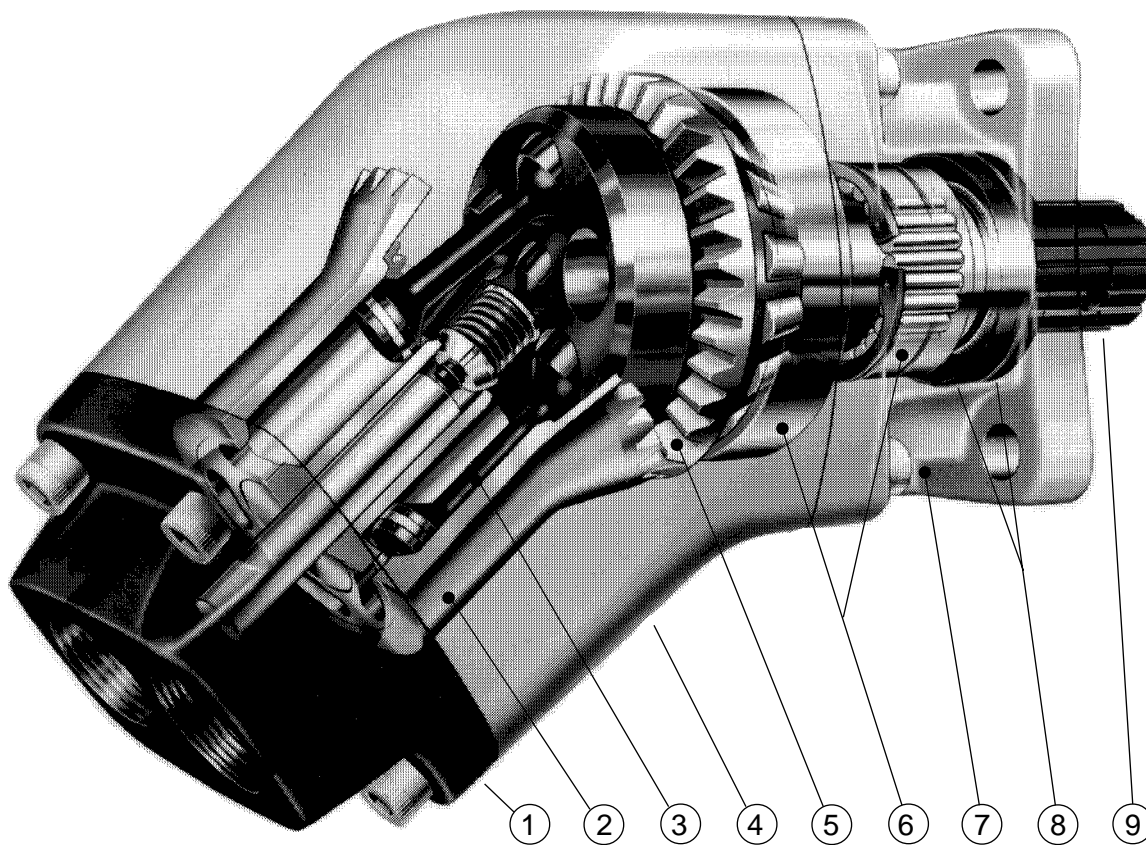

### Legend

- |                           |                   |                               |
|---------------------------|-------------------|-------------------------------|
| 1 End cap                 | 4 Barrel housing  | 7 Bearing housing with flange |
| 2 Cylinder barrel         | 5 Timing gear     | 8 Shaft seals                 |
| 3 Piston with piston ring | 6 Roller bearings | 9 Input shaft                 |

## Pump and line selection

### Pump selection

A suitable pump size for a truck application can be selected as follows:

#### Operating conditions

As an example, a cargo crane specifies:

- Flow: 60-80 l/min
- Pressure: 230 bar
- Diesel engine speed  $\approx$  800 rpm

#### Determine pump speed

A Volvo type BKUH 1123 PTO on gearbox SR 1700, for example, has a gear ratio of 1:1.54.

The pump speed will be:

- $800 \times 1.54 \approx 1200$  rpm

#### Select a suitable pump size

Use diagram 1 and select a pump that will provide 60 - 80 l/min at 1200 rpm.

Follow line 'a' (1200 rpm) until it crosses line 'b' (70 l/min).

- F1-60 is a suitable choice

#### Required input torque

Make sure the PTO and the gearbox tolerates the pump torque. Use diagram 2 to obtain the required pump torque.

Follow a line from 'c' (230 bar) until it crosses the F1-60 line (the selected pump).

- Read 220 Nm (at 'd')

**NOTE:** A rule-of-thumb is to select the highest PTO ratio and the smallest pump size that meets the crane specification without exceeding the pump speed, pressure, and power limitations shown in the specifications on page 4.

### Pipe/line selection

Flow speeds shown in the table to the right should not be exceeded in order to obtain lowest noise and heat generation.

Select, from the lower table, the smallest line dimension that meets the flow speed recommendations.

- At 70 l/min a 38 mm suction line and a 19 mm pressure line is needed.

**Note:** Long lines may require larger dimensions.

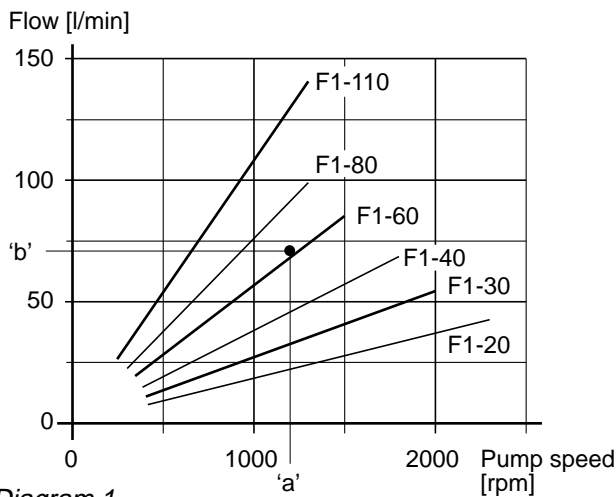

Diagram 1.

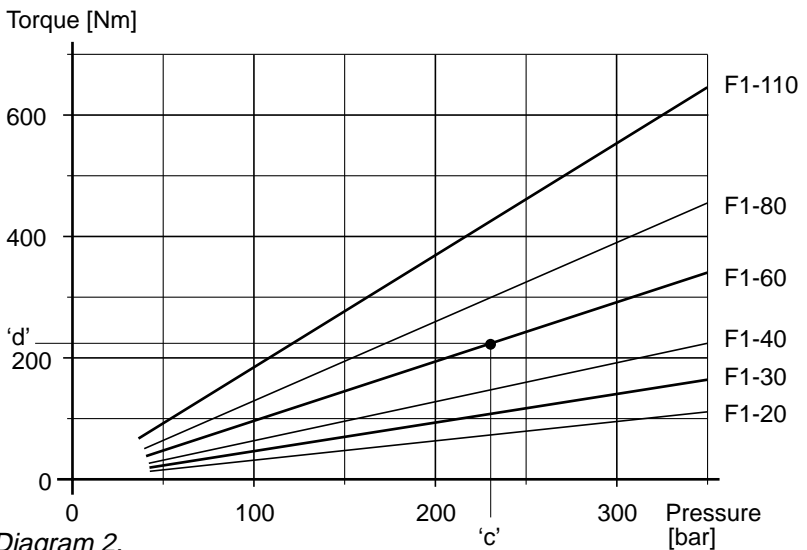

Diagram 2.

Line type	Pressure [bar]	Flow speed [m/s]
Suction	-	0.5 - 1
Pressure	100 - 300	3 - 5

Fluid flow [l/min]	Flow speed [m/s] at indicated line size					
	19 mm	25 mm	32 mm	38 mm	50 mm	
25	1.5	0.8	0.5	(0.4)	(0.2)	Suction line
50	2.9	1.7	1.0	0.7	(0.4)	
75	4.4	2.5	1.6	1.1	0.6	
100	(5.9)	3.4	2.1	1.5	0.8	Pressure line
150	(8.8)	(5.1)	3.1	2.2	1.3	

### Ordering code

Example: **F1 - 80 - R**

F1 frame size   
**20, 30, 40, 60, 80 or 110**

Shaft rotation   
**R** Right hand  
**L** Left hand

### Standard versions

Designation	Ordering no.
F1-20-R	370 4520
F1-30-R	370 4530
F1-40-R	370 3940
F1-60-R	370 3960
F1-80-R	379 6380
F1-110-R	370 9110

## Installations dimensions

(Right hand F1-110 shown)

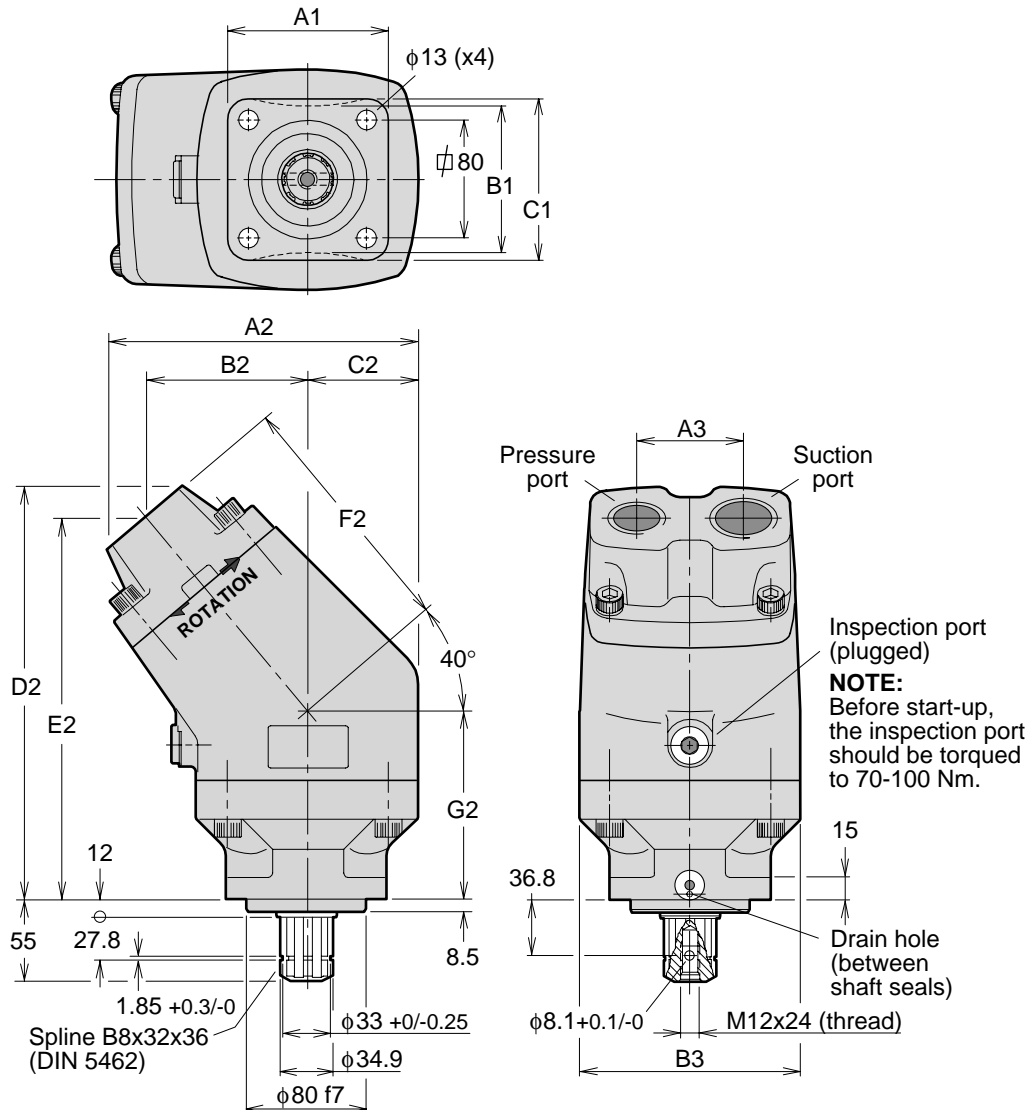

Frame size	F1-20	F1-30	F1-40	F1-60	F1-80	F1-110
A1	106	106	109	109	108	109
B1	98	98	98	98	98	109
C1	104	104	109	109	106	109
A2	144	145	163	167	203	208
B2	73	75	82	86	109	109
C2	53	53	60	60	68	74
D2	206	208	234	238	277	277
E2	191	194	217	221	256	256
F2	114	117	128	134	169	169
G2	104	104	119	119	127	127
A3	48	48	60	60	60	72
B3	106	106	114	114	120	148
Pressure port *	1/2"	1/2"	3/4"	3/4"	1"	1"
Suction port *	3/4"	3/4"	1"	1"	1 1/4"	1 1/4"

\* Pressure and suction ports are BSP.

## Installation and start-up

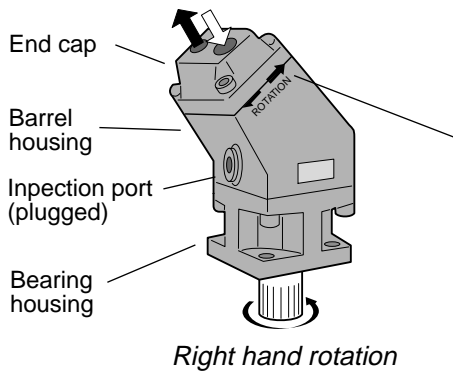

Right hand rotation

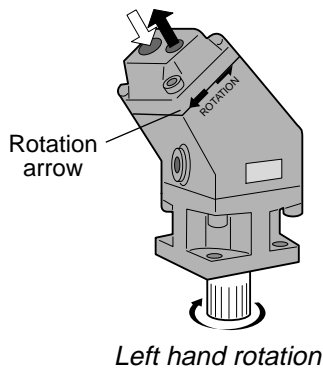

Left hand rotation

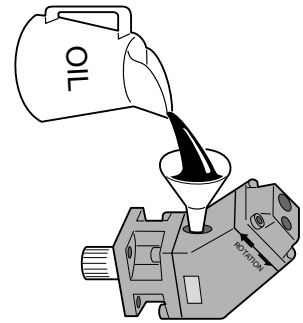

Before start-up, the housing must be filled with hydraulic fluid.

### Direction of rotation

The pictures above show direction of flow vs. shaft rotation. The direction of rotation can be changed (i. e. from right hand to left hand) by turning the end cap. Remove the inspection port plug and turn the shaft until the marked teeth of the timing gear and cylinder barrel are visible through the port opening.

Remove the four cap screws and turn the end cap 180° while making sure it stays in contact with the barrel housing. Re-fit the cap screws and torque to 50 - 70 Nm on F1-20 to -60. For the F1-80 and F1-110 torque to 80 - 100 Nm.

Check that the marked teeth are still properly engaged. Re-fit the plug (use a new washer) and torque to 70 - 100 Nm.

### Installation

The robust shaft bearings allow the F1 to be mounted either on a bracket, driven by a belt or a prop-shaft, or directly on a PTO.

The illustration to the right shows three ways of installing a gear on the F1 shaft. The pump shaft spline end usually fits directly in the PTO internal spline coupling.

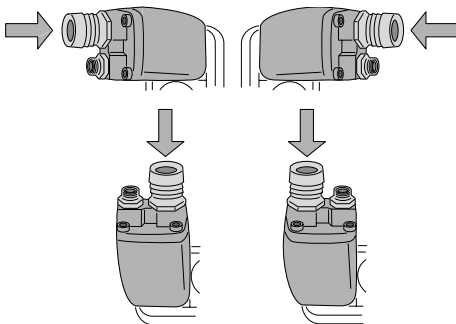

**NOTE:** - The suction port should always be above the pressure port when the pump is installed above the reservoir oil level.  
- During operation, the pump must be filled with oil to at least 50%.

### Fluids

The F1 data shown in the specification on page 4 are valid when operating on high quality, mineral based fluid.

Hydraulic fluids type HLP (DIN 51524), ATF (automatic transmission fluids), and API type CD engine oils are suitable.

### Fluid temperature

Main circuit: Max 75 °C

### Viscosity

Recommended viscosity: 20 to 30 mm<sup>2</sup>/s (cSt).

Operating viscosity limits: min 10 mm<sup>2</sup>/s, max 400 mm<sup>2</sup>/s.

At start-up: max 1000 mm<sup>2</sup>/s.

### Drain line

F1 pumps don't need an external drain line as they are internally drained.

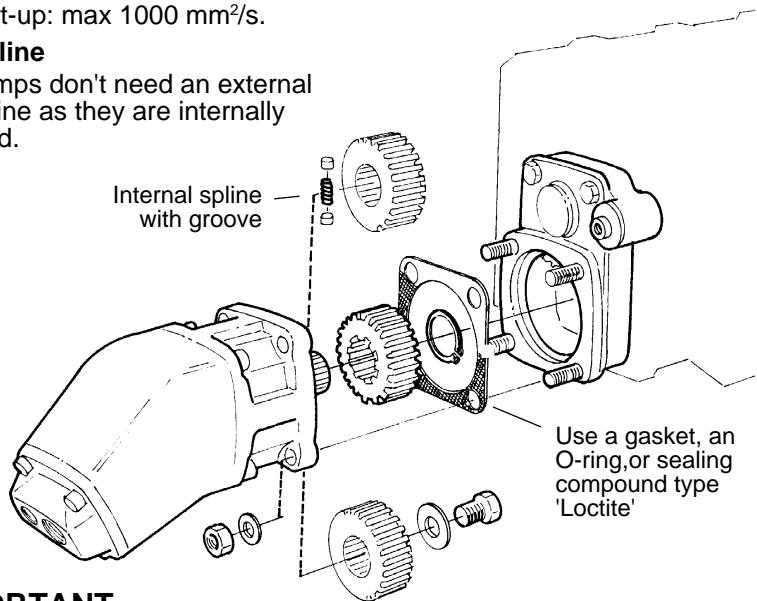

### IMPORTANT

Our special tool (part no. 370 6851) facilitates installing couplings, sleeves, and gears on the pump shaft. Force must never be used when installing these parts on the F1 shaft.

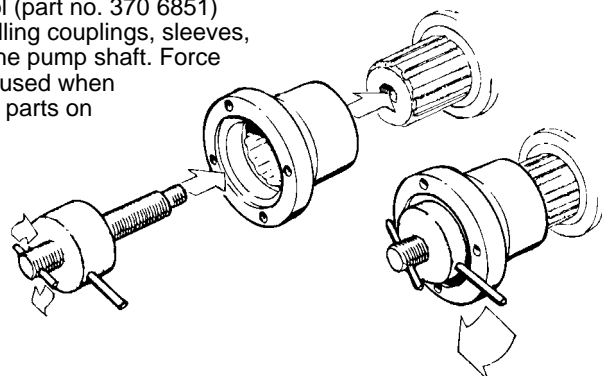

---

Please contact our sales representative:



[www.utah-hydraulique.com](http://www.utah-hydraulique.com)



**Parker Hannifin AB**  
VOAC Hydraulics Division  
SE-461 82 Trollhättan  
Sweden  
Tel +46 520 986 00  
Fax +46 520 371 05  
[www.parker.com](http://www.parker.com)

Catalog 9129 8201-02  
Ed. 1298-9915 GB