



Return Filters

E 043 • E 072

- Tank top mounting
- Connection up to G $\frac{3}{4}$
- Nominal flow rate up to 70 l/min

Description

Application

In the return line circuits of hydraulic systems.

Performance features

Protection

against wear: By means of filter elements that, in full-flow filtration, meet even the highest demands regarding cleanliness classes.

Protection against malfunction: By means of full-flow filtration in the system return, the pumps above all are protected from dirt particles remaining in the system after assembly, repairs, or which are generated by wear or enter the system from outside.

Special features

By-pass valve: The location close to the inlet port prevents dirt particles retained by the filter element from entering into the clean oil side.

Removable bowl: In case of maintenance the filter bowl is removed together with the filter element - therefore dirt particles are not flushed back into the tank.

Extension pipe: Easy and fast adaptation to various lengths due to the "do-it-yourself"-system.

Filter elements

Flow direction from outside to centre. The star-shaped pleating of the filter material results in:

- large filter surfaces
- low pressure drop
- high dirt-holding capacities
- long service life

Ventilating filter

Ventilation of the reservoir by an integral star-shape pleated filter element:

- removable (replace annually!)
- splash-proof
- fineness 2 µm

Filter maintenance

By using a clogging indicator the correct moment for maintenance is stated and guarantees the optimum utilization of the filter life.

Materials

Screw-on cap: Polyamide, GF reinforced
Filter head: Aluminium alloy
Filter bowl: Polyamide, CF reinforced, electrically conducting
Seals: NBR (Viton on request)
Filter media: EXAPOR®MAX - inorganic multi-layer microfibre web
Paper - cellulose web, impregnated with resin

Accessories

An optional oil separator (Part No. E 043.1701) prevents oil splashing through the ventilating filter at mobile applications.

Electrical and optical clogging indicators are available. Dimensions and technical data see catalogue sheet 60.20.

For mounting of extension pipes ("do-it-yourself"-system) the following parts are needed:

Aluminium pipe (Length xxx in mm)	Part No. FR 043.Lxxx
O-Ring	Part No. N 007.0203
Crimping tool	Part No. FR 043.1770

Characteristics

Nominal flow rate

Up to 70 l/min (see Selection Chart, column 2)

The nominal flow rates indicated by ARGO-HYTOS are based on the following features:

- closed by-pass valve at $v \leq 200 \text{ mm}^2/\text{s}$
- element service life > 1000 operating hours at an average fluid contamination of 0,07 g per l/min flow volume
- flow velocity in the connection lines $\leq 4,5 \text{ m/s}$

Connection

Threaded ports according to ISO 228 or DIN 13.

Sizes see Selection Chart, column 6 (other port threads on request)

Filter fineness

5 µm(c) ... 30 µm(c)

β-values according to ISO 16889

(see Selection Chart, column 4 and diagram Dx)

Dirt-holding capacity

Values in g test dust ISO MTD according to ISO 16889

(see Selection Chart, column 5)

Hydraulic fluids

Mineral oil and biodegradable fluids

(HEES or HETG, see info-sheet 00.20)

With high filling conditions we recommend an electrical conductivity $\geq 500 \text{ pS/m}$ at 20 °C.

Temperature range

- 30 °C ... + 100 °C (temporary - 40 °C ... + 120 °C)

Viscosity at nominal flow rate

- at operating temperature: $v < 60 \text{ mm}^2/\text{s}$
- as starting viscosity: $v_{\text{max}} = 1200 \text{ mm}^2/\text{s}$
- at initial operation: The recommended starting viscosity can be read from the diagram D (pressure drop as a function of the kinematic viscosity) as follows: Find the 70% Δp of the cracking pressure of the by-pass valve on the vertical axis. Draw a horizontal line so that it intersects the Δp curve at a point. Read this point on the horizontal axis for the viscosity.

Operating pressure

Max. 10 bar

Mounting position

Preferably vertical, outlet downwards

Diagrams

Δp-curves for complete filters in Selection Chart, column 3

D1 Pressure drop as a function of the **flow volume** at $v = 35 \text{ mm}^2/\text{s}$ (0 = casing empty)

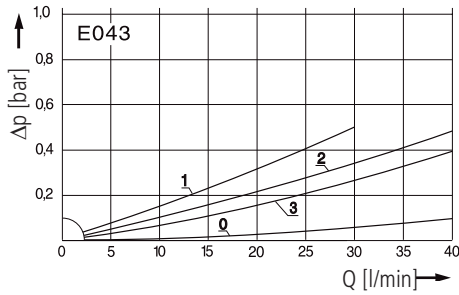

Pressure drop as a function of the **kinematic viscosity** at nominal flow

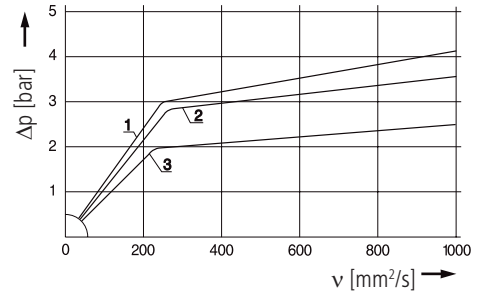

D2 Pressure drop as a function of the **flow volume** at $v = 35 \text{ mm}^2/\text{s}$ (0 = casing empty)

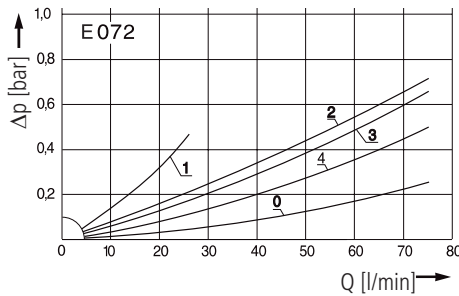

Pressure drop as a function of the **kinematic viscosity** at nominal flow

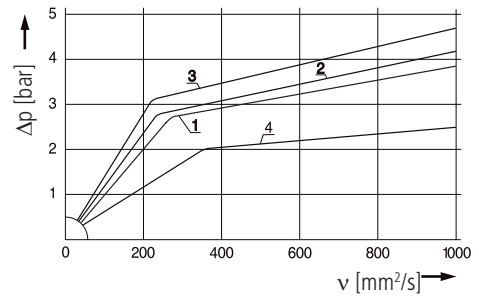

Filter fineness curves in Selection Chart, column 4

Dx Filtration ratio β as a function of particle size x obtained by the Multi-Pass-Test according to ISO 16889

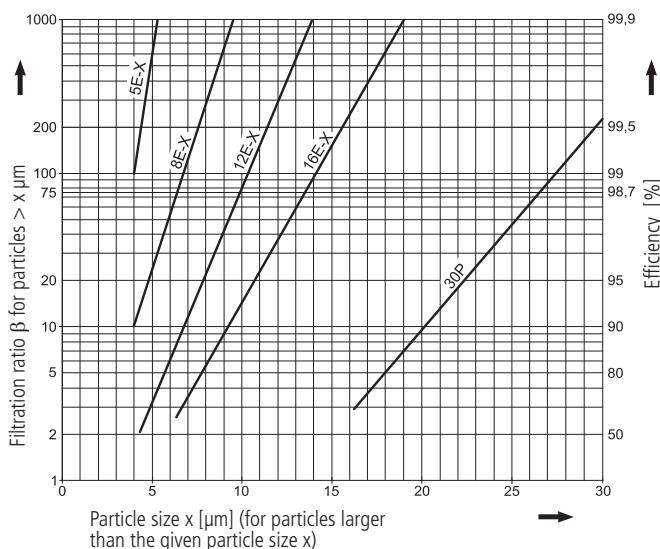

The abbreviations represent the following β -values resp. finenesses:

For EXAPOR®MAX- and Paper elements:

- 5 E-X = $\bar{\beta}_{5(c)}$ = 200 EXAPOR®MAX
- 8 E-X = $\bar{\beta}_{8(c)}$ = 200 EXAPOR®MAX
- 12 E-X = $\bar{\beta}_{12(c)}$ = 200 EXAPOR®MAX
- 16 E-X = $\bar{\beta}_{16(c)}$ = 200 EXAPOR®MAX
- 30 P = $\bar{\beta}_{30(c)}$ = 200 Paper

Based on the structure of the filter media of the 30 P paper elements, deviations from the printed curves are quite probable.

For screen elements:

- 40 S = screen material with mesh size 40 μm
- 60 S = screen material with mesh size 60 μm
- 100 S = screen material with mesh size 100 μm

Tolerances for mesh size according to DIN 4189

For ventilating filter elements:

- 2 CL = 99,5 % efficiency for particles of size 2 μm

For special applications, finenesses differing from these curves are also available by using special composed filter material.

Selection Chart

Part No.	Nominal flow l/min	Pressure drop see diagram D/curve no.	Filter fineness see Diagr. Dx	Dirt-holding capacity g	Connection A	Cracking pressure of by-pass bar	Symbol	Replacement element Part No.	Weight kg	Replacement ventilating filter Part No. (Filter fineness see diagrams)	Remarks
1	2	3	4	5	6	7	8	9	10	11	12
E 043-156	25	D1/1	12 E-X	5,3	G ¹ / ₂	2,5	2	V3.0510-56	0,6	L1.0403-01 (2 CL)	-
E 043-166	25	D1/1	12 E-X	5,3	G ¹ / ₂	2,5	1	V3.0510-56	0,6	-	-
E 043-158	35	D1/2	16 E-X	5,7	G ¹ / ₂	2,5	2	V3.0510-58	0,6	L1.0403-01 (2 CL)	-
E 043-168	35	D1/2	16 E-X	5,7	G ¹ / ₂	2,5	1	V3.0510-58	0,6	-	-
E 043-151	30	D1/3	30 P	4,0	G ¹ / ₂	1,5	2	P3.0510-51	0,6	L1.0403-01 (2 CL)	-
E 043-161	30	D1/3	30 P	4,0	G ¹ / ₂	1,5	1	P3.0510-51	0,6	-	-
E 072-153	25	D2/1	5 E-X	6,7	G ³ / ₄	2,5	2	V3.0520-53	0,8	L1.0403-01 (2 CL)	-
E 072-163	25	D2/1	5 E-X	6,7	G ³ / ₄	2,5	1	V3.0520-53	0,8	-	-
E 072-156	50	D2/2	12 E-X	11	G ³ / ₄	2,5	2	V3.0520-56	0,8	L1.0403-01 (2 CL)	-
E 072-166	50	D2/2	12 E-X	11	G ³ / ₄	2,5	1	V3.0520-56	0,8	-	-
E 072-158	70	D2/3	16 E-X	12	G ³ / ₄	2,5	2	V3.0520-58	0,8	L1.0403-01 (2 CL)	-
E 072-168	70	D2/3	16 E-X	12	G ³ / ₄	2,5	1	V3.0520-58	0,8	-	-
E 072-151	50	D2/4	30 P	6,6	G ³ / ₄	1,5	2	P3.0520-51*	0,8	L1.0403-01 (2 CL)	-
E 072-161	50	D2/4	30 P	6,6	G ³ / ₄	1,5	1	P3.0520-51*	0,8	-	-

All filters are delivered with a plugged clogging indicator connection M12 x 1,5. As clogging indicators either manometers or electrical pressure switches can be used. Optional extension pipes adapt the filter length to various tank depths. For ordering of accessories please use the below mentioned codes.

Order example: The filter E 072-156 has to be supplied with an extension pipe (EV) for a mounting depth of 495 mm.

Order description: E 072-156 / EV 495

Part No. (basic unit) _____

Extension pipe (5 various lengths are available) _____

EV = K + 65 / + 115 / + 215 / + 315 / + 415 mm (see dimensions and measurements)

For the appropriate clogging indicators see catalogue sheet 60.20.

Remarks:

- The switching pressure of the electrical pressure switch has always to be lower than the cracking pressure of the by-pass valve (see Selection Chart, column 7).
- The clogging indicators are optionally available and will then be loosely provided.
- The filters listed in this chart are standard filters. Other designs available on request.

* Paper media supported with metal gauze

Dimensions

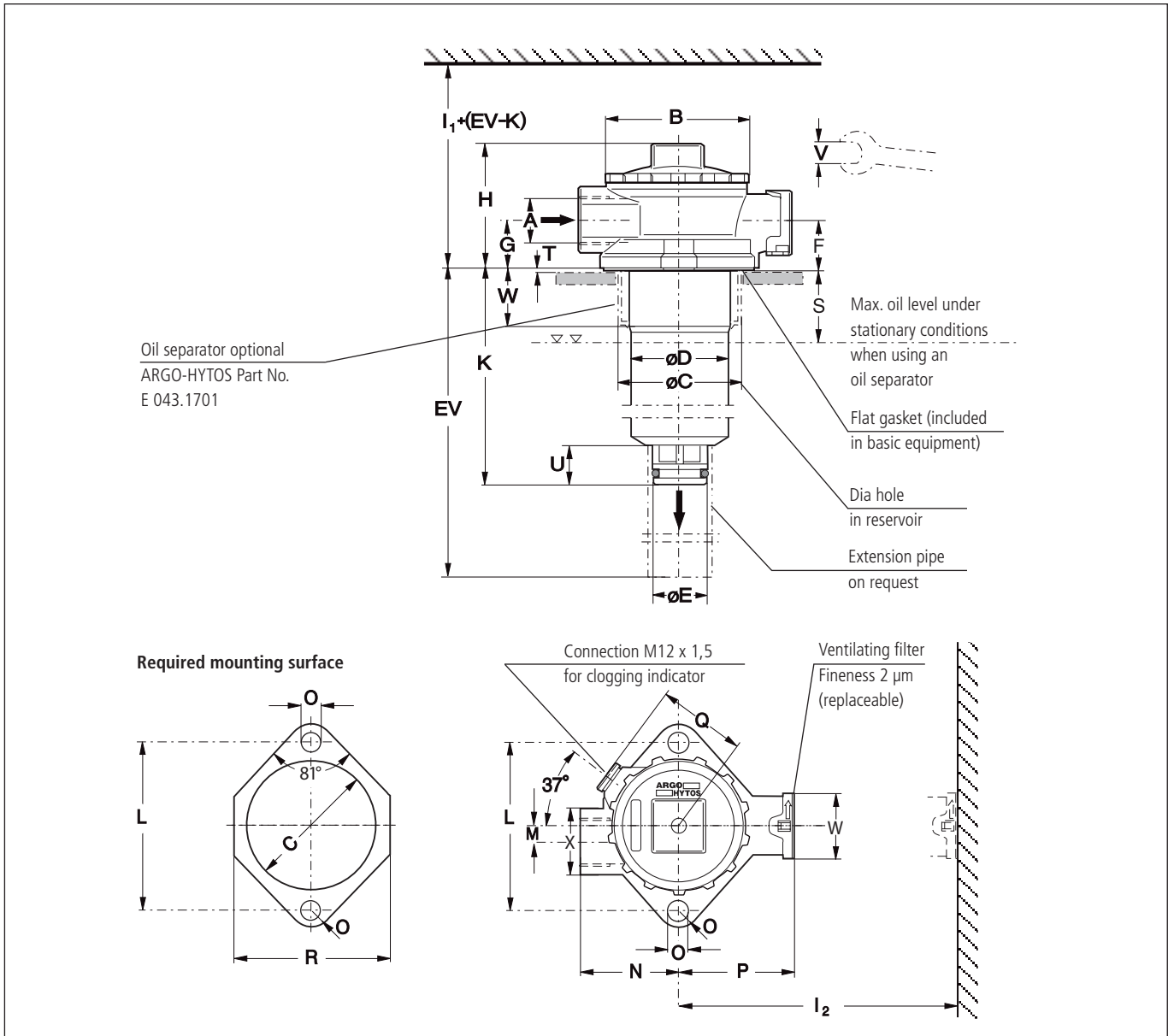

Measurements

Type	A	B	C	D	E	F	G	H	I ₁	I ₂	K	L	M	N	O	P	Q	R	S	T
E 043	G ^{1/2}	75	min./max. 60/63	51	27,8	24	26	67	175	110	83	88	9	51	11	59,5	46	79	42	2
E 072	G ^{3/4}	75	60/63	51	27,8	24	26	67	270	110	180	88	9	51	11	59,5	46	79	42	2
Type	U	V	W	X																
E 043	21	SW 27	35	SW 36																
E 072	21	SW 27	35	SW 36																

Symbols

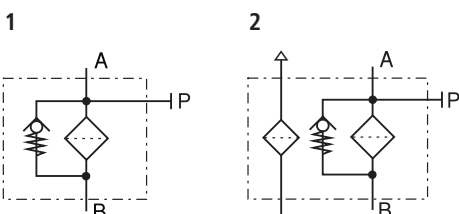

Spare Parts

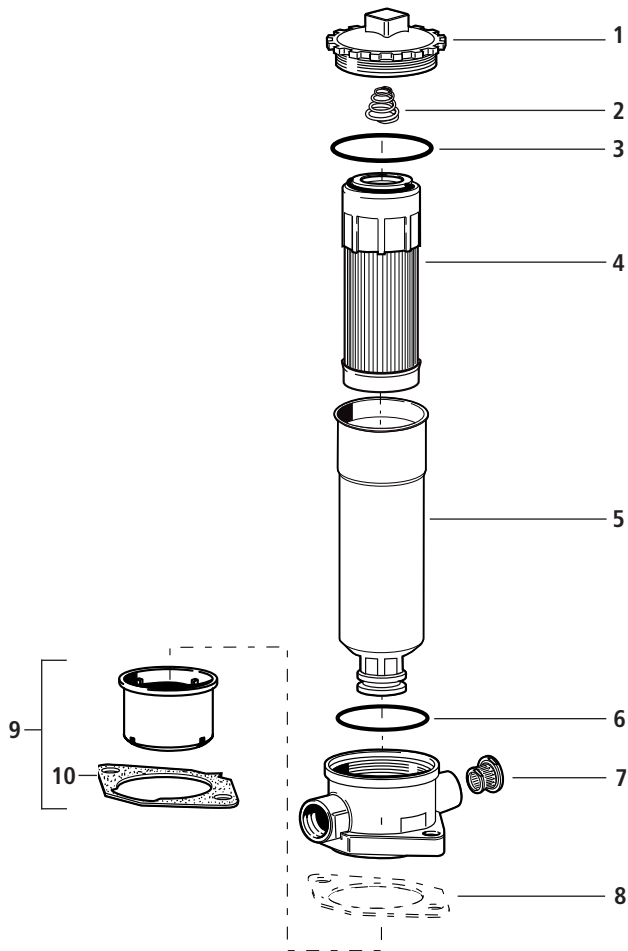

Pos.	Designation	Part No.
1	Screw-on cap	FR 043.0201
2	Compression spring	N 015.1606
3	O-ring 57 x 3	N 007.0573
4	Filter element	see Chart / col. 9
5	Filter bowl E043 *	FR 043.0107
5	Filter bowl E072 *	FR 072.0104
6	O-ring 50 x 2	N 007.0501
7	Ventilating filter	L1.0403-01
8	Flat gasket (for versions without oil separator)	D 043.0113
9	Oil separator with Pos. 10	E 043.1701
10	Flat gasket (for versions with oil separator)	D 043.0118

* Specify mounting depth (EV) in mm

The functions of the complete filters as well as the outstanding features of the filter elements assured by ARGO-HYTOS can only be guaranteed if original ARGO-HYTOS spare parts are used.

Quality Assurance

Quality management according to DIN EN ISO 9001

To ensure constant quality in production and operation, ARGO-HYTOS filter elements undergo strict controls and tests according to the following DIN and ISO standards:

- DIN ISO 2941** Verification of collapse/burst resistance
- DIN ISO 2943** Verification of material compatibility with fluids
- DIN ISO 3724** Verification of flow fatigue characteristics

- ISO 2942**
- ISO 3968**
- ISO 16889**

Verification of fabrication integrity (Bubble Point Test)
 Evaluation of pressure drop versus flow characteristics
 Multi-Pass-Test (evaluation of filter fineness and dirt-holding capacity)

Various quality controls during the production process guarantee the leakfree function and solidity of our filters.

Our engineers will be glad to advice you in questions concerning filter application, selection as well as the cleanliness class of the filtered medium attainable under practical operating conditions.

Illustrations may sometimes differ from the original. ARGO-HYTOS is not responsible for any unintentional mistake in this specification sheet.



We produce fluid power solutions

ARGO-HYTOS GMBH · Industriestraße 9 · D-76703 Kraichtal

Tel: +49 7250 76-0 · Fax: +49 7250 76-199 · info.de@argo-hytos.com · www.argo-hytos.com